

User's Guide

Agilent Technologies
ESA-E Series Spectrum Analyzers
Option B7K Distance to Fault Accessory Kit
Kit Part Number E4402-60009



Agilent Part Number E4402-90012

Printed in USA May 2000

Notice.

The information contained in this document is subject to change without notice.

Agilent Technologies makes no warranty of any kind with regard to this material, including but not limited to, the implied warranties of merchantability and fitness for a particular purpose. Agilent Technologies shall not be liable for errors contained herein or for incidental or consequential damages in connection with the furnishing, performance, or use of this material.

General Information

Introduction

Option B7K Distance to Fault Accessory Kit has been assembled to ensure that you have the necessary ancillary equipment to set up the Cable Fault Location, Return Loss, and Loss/Gain measurements. Because your site installation may be unique, you must provide any additional connectors, adaptors, and cables to make the final connections to your system equipment. This document describes and illustrates the measurement and normalization configurations needed for each measurement. For more information on performing the measurement or measurement normalization, you must refer to the measurement instructions located in the *ESA-E Series Spectrum Analyzers GSM Measurement Personality Measurement Guide* or the *ESA-E Series Spectrum Analyzers cdmaOne Measurement Personality Measurement Guide*.

Option B7K Accessory Kit Contents

The Option B7K Accessory Kit contains the devices listed below.

Item	Description	Specifications	Quantity	Part Number
1	RF Bridge	300 kHz to 6 GHz Type N 50 ohm	1	86205A
2	Power Divider	DC to 18 GHz Type N 50 ohm	1	11636A
3	Coaxial Termination	DC to 18 GHz Type N(m) 50 ohm	1	909A Option 012
4	Coaxial Short	DC to 18 GHz Type N(m)	1	11512A
5	Coaxial Cable	2 Foot Type N-N 50 ohm	2	8121-0101
6	Coaxial Attenuator	DC to 18 GHz Type N(m) 50 ohm	2	0955-0826

Cable Fault Location Measurement Setup

Purpose

To make the Cable Fault Location measurements using the Option B7K Accessory Kit, set up the equipment as illustrated below.

Measurement Normalization Setup

Connect the tracking generator output, power divider, coaxial short (or open), 6 dB attenuator (optional), and the spectrum analyzer RF input as shown in Figure 1-1. For more information on performing the measurement normalization, refer to the Cable Fault Location measurement in the *ESA-E Series Spectrum Analyzers GSM Measurement Personality Measurement Guide*.

Figure 1-1 Normalizing the Measurement

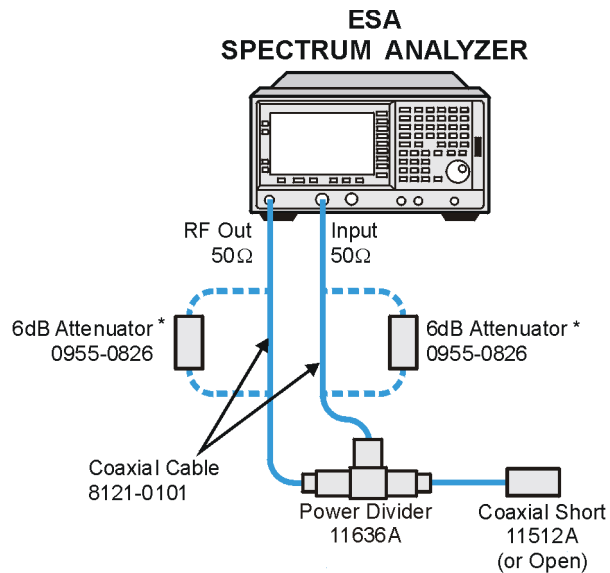

* The two 6dB Attenuators may be used to improve impedance matching

pt71

Measurement Setup

Connect the tracking generator output, power divider, cable under test, 6 dB attenuator (optional), and the spectrum analyzer RF input as shown in Figure 1-2. For more information on performing the measurement, refer to the Cable Fault Location measurement in the *ESA-E Series Spectrum Analyzers GSM Measurement Personality Measurement Guide*.

Figure 1-2 **Measurement Setup**

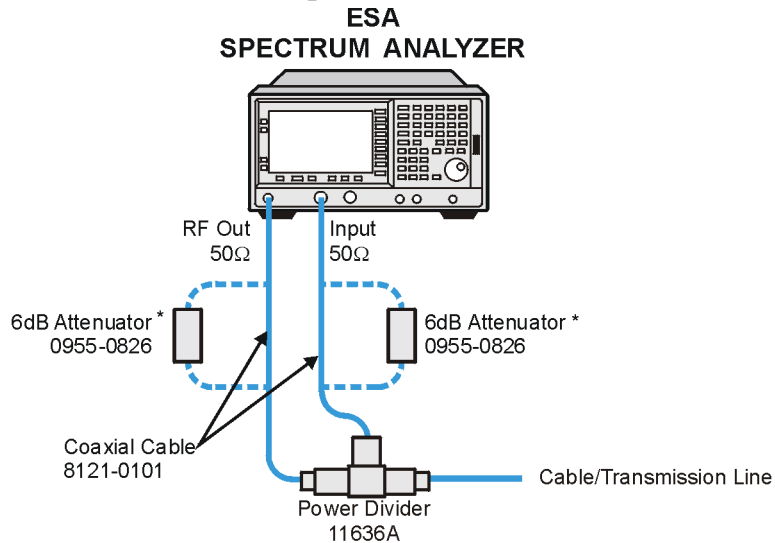

* The two 6dB Attenuators may be used to improve impedance matching

pt72

Return Loss Measurement Setup

Purpose

To make the Return Loss Location measurements using the Option B7K Accessory Kit, set up the equipment as illustrated below.

Measurement Normalization Setup

Connect the tracking generator output, RF bridge, coaxial short (or open), 6 dB attenuator (optional), and the spectrum analyzer RF input as shown in Figure 1-3. For more information on performing the measurement normalization, refer to the Return Loss measurement in the *ESA-E Series Spectrum Analyzers GSM Measurement Personality Measurement Guide* or *ESA-E Series Spectrum Analyzers cdmaOne Measurement Personality Measurement Guide*.

Figure 1-3 Normalizing the Measurement

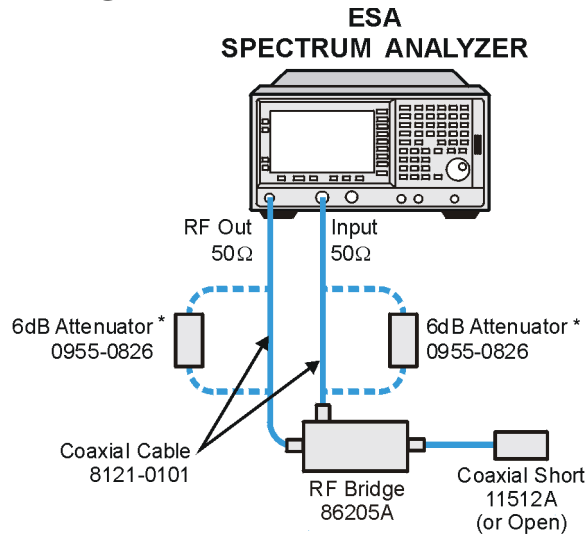

* The two 6dB Attenuators may be used to improve impedance matching

pt73

Measurement Setup

Connect the tracking generator output, RF bridge, device under test, 50 ohm load (if the device is a two-port device), 6 dB attenuator (optional), and the spectrum analyzer RF input as shown in Figure 1-4. For more information on performing the measurement, refer to the Return Loss measurement in the *ESA-E Series Spectrum Analyzers GSM Measurement Personality Measurement Guide* or *ESA-E Series Spectrum Analyzers cdmaOne Measurement Personality Measurement Guide*.

Figure 1-4 Measurement Setup

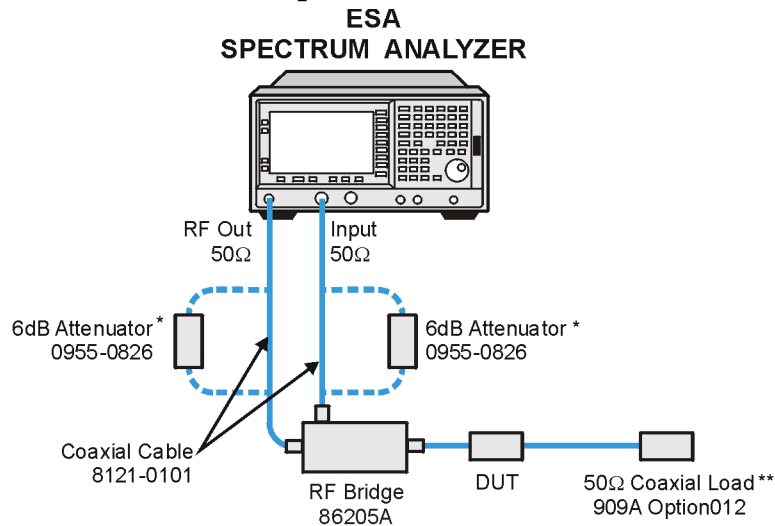

* The two 6dB Attenuators may be used to improve impedance matching

** The 50Ω Load must be used if the DUT is a two-port device

pt74

Loss/Gain Measurement Setup

Purpose

To make the Loss/Gain measurements using the Option B7K Accessory Kit, set up the equipment as illustrated below.

Measurement Normalization Setup

Connect the tracking generator output, 6 dB attenuator (optional), and the spectrum analyzer RF input as shown in Figure 1-5. For more information on performing the measurement normalization, refer to the Loss/Gain measurement in the *ESA-E Series Spectrum Analyzers GSM Measurement Personality Measurement Guide* or *ESA-E Series Spectrum Analyzers cdmaOne Measurement Personality Measurement Guide*.

Figure 1-5 Normalizing the Measurement

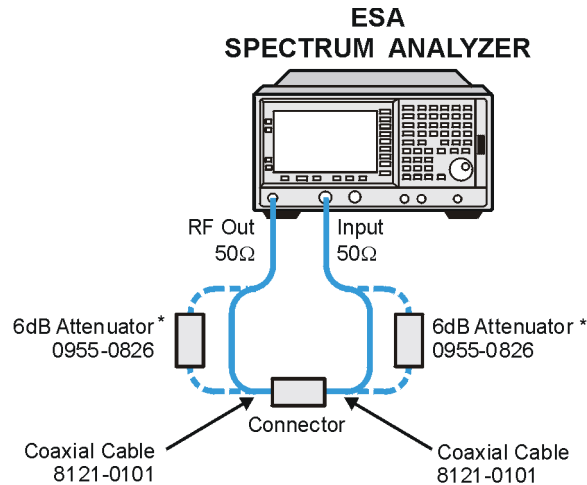

* The two 6dB Attenuators may be used to improve impedance matching

pt75

Measurement Setup

Connect the tracking generator output, device under test, 6 dB attenuator (optional), and the spectrum analyzer RF input as shown in Figure 1-6. For more information on performing the measurement, refer to the Loss/Gain measurement in the *ESA-E Series Spectrum Analyzers GSM Measurement Personality Measurement Guide* or *ESA-E Series Spectrum Analyzers cdmaOne Measurement Personality Measurement Guide*.

Figure 1-6 Measurement Setup

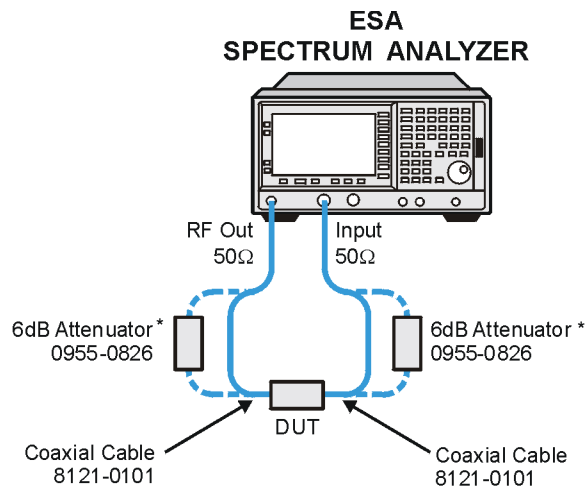

* The two 6dB Attenuators may be used to improve impedance matching

pt76